

PRELIMINARY SERVICE MANUAL

 Infinity® **HPS 500**

POWERED SUBWOOFER



Infinity Systems Incorporated
250 Crossways Park Dr.
Woodbury, New York 11797

- CONTENTS -

SPECIFICATIONS	2
SET-UP GUIDE	3
CONTROLS	6
OPERATION	7
PARTS LIST	9
SCHEMATICS	16

Infinity HPS-500

500w Powered Sub Amp SPECIFICATIONS

Frequency response 22Hz - 120Hz
 Drive Unit 15" Woofer

Weight	77.2 lbs./35kg			
Dimensions (H x W x D)	22 7/16" (502 x 483 x 570mm)			
LINE VOLTAGE 120VAC/60Hz				
LINE VOLTAGE 230VAC/50Hz				

Parameter	Specification	Unit	Limits	Conditions	Notes
Amp Section					
Type (Class AB, D, other)	AB Bridged	--	--	BASH® Power Supply	
Load Impedance (speaker)	20	Ohms	--	Nominal	Z-curve required
Rated Output Power	500	Watts	400	1 input driven	
THD@ Rated Power	0.1	%	1	22k filter	500w
THD @ 1 Watt	0.3	%	1	22k filter	
Polarity	0	deg.	0° ±20	In phase at 50Hz in Direct Mode	.250 faston (+).....205 faston (-)
DC Offset	20	mV-DC	50	@ Speaker Outputs	
Damping factor	>200	DF	--		
Input Sensitivity					
Input Frequency	31	Hz	31	Nominal Freq.	1 input driven
Line Input	350	mVrms	±2dB	To Rated Power	1 input driven
Speaker/Hi Level Input	8	Vrms	±2dB	To Rated Power	(-26dB below Line In)...1 input driven
Signal to Noise					
SNR-A-Weighted	100	dB	90	relative to rated power	A-Weighting filter
SNR-unweighted	70	dB	70	relative to rated power	22k filter
SNR rel. 1W-unweighted	60	dB	55	relative to 1W Output	22k filter
Residual Noise Floor	2	mVrms	3	Volume @max, using RMS reading	DMM/VOM (or A/P)
Residual Noise Floor	1.5	mVrms(max)	2	Volume @max, w/ A/P Swept Bandpass Measurement	(Line freq.+ harmonics)
Input Impedance					
Line Input	3k	ohms	N/A		
Speaker/Hi Level Input	470	ohms	N/A		
Active Filters					
Low Pass (fixed or variable)	Variable			Note: Center position = 100Hz	
Low Pass filter (point or range)	45-120	Hz	±2dB		
Slope	12	dB/Octave	n/a		
Q	0.707	Damping	n/a		
Normal-Direct Switch					
yes	--		functional		
Low Pass filter (point or range)	160 (direct), 45-120 (normal)	Hz	±2dB		
Slope	12	dB/Octave	--		
Q	--	Damping	--		
Subsonic filter (HPF)	31	Hz	±2dB		
Slope	12	dB/Octave	--		
Q	--	Damping	--		
Video Boost Switch					
yes	--		--		
Boost	+3	dB	--		
Range	40-80	Hz	--		
Features					
Limiters	--				
Line Out Crossover Switch					
Phase Switch	--		functional		
Line Output (80Hz HPF-unity gain)	--		functional		
Volume pot Taper (lin/log)	log	--	functional		
Input Configuration					
Line Out: 80/120/160Hz HPF	80/120/160	Hz	functional		
Slope	6	dB/Octave	functional		
Q	0.707	Damping	functional		
Power on Delay time					
>3	sec.		>3	AC Power Applied	
Transients/Pops					
ATO Transient	10	mV-peak	20	@ Speaker Outputs	
Turn-on Transient	500	mV-peak	1v-pp	@ Speaker Outputs	AC Line cycled from OFF to ON
Turn-off Transient	500	mV-peak	1v-pp	@ Speaker Outputs	AC Line cycled from ON to OFF
Efficiency					
Stand-by Input Power	10	Watts	15	@ nom. line voltage	
Power Cons.@rated power	670	Watts	N/A	@ nom. line voltage	
Protection					
Thermal Protection	yes		functional		Decreases gain at 113°C -1.3dB
DC Offset Protection	yes		functional	DC present at Speaker Out leads	Relay or crowbar (for driver/fire protection)
Line Fuse Rating	6	Amps	functional	Type-T or Slo Blo	External fuse with UL/SEMKO rated holder

CONNECTING YOUR SUBWOOFER

If your receiver/processor does not have subwoofer outputs for the left and right channels:

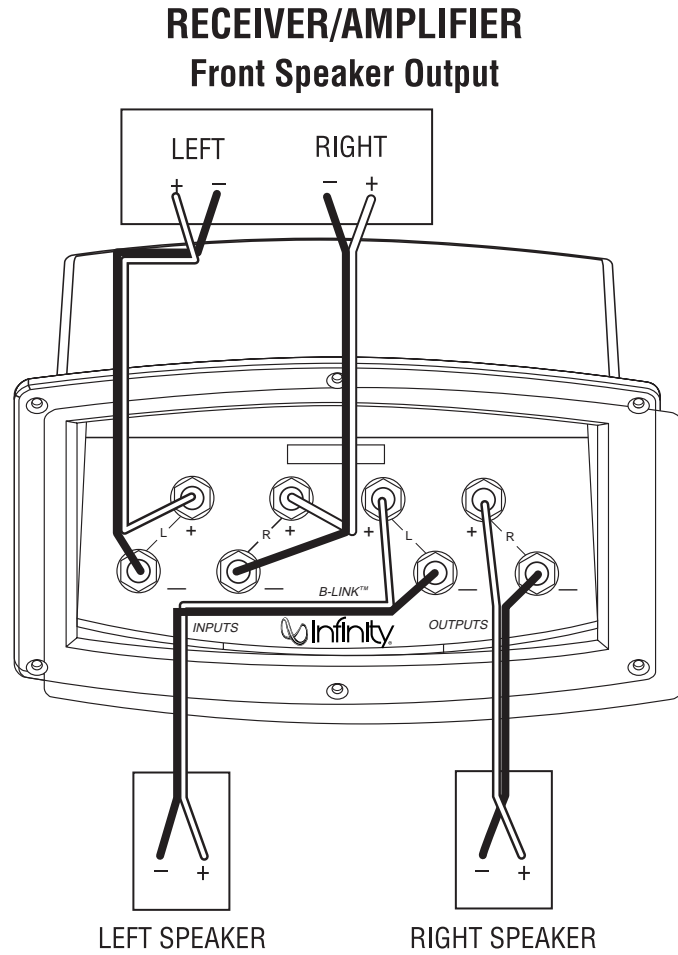

CONNECTING YOUR SUBWOOFER (Continued)

NOTE: Some receivers have a single subwoofer output (do not confuse this with a single LFE output as described below). In that case, it is recommended that you use a Y connector (not included) to maximize performance.

If your receiver/processor has subwoofer outputs for the left and right channels:

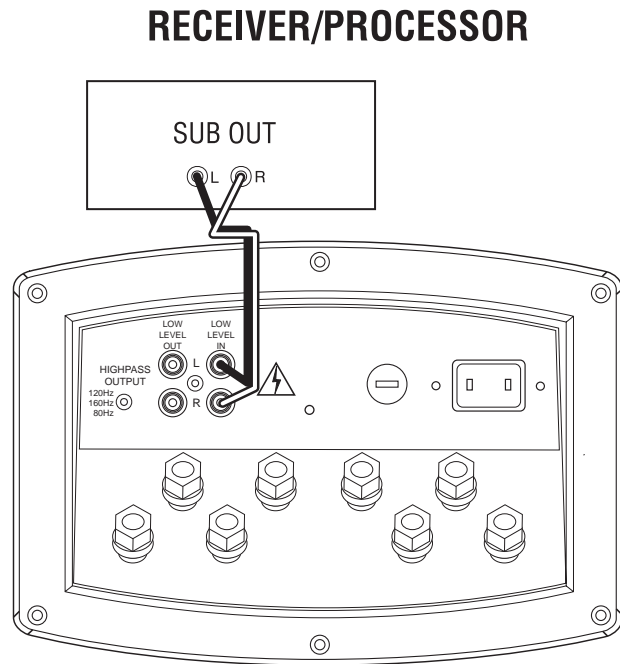

NOTE: In this case, you do not need to use a Y connector. Simply connect the LFE output on your receiver/processor to either the left or right input on the subwoofer.

If you have a Dolby* Digital or DTS® receiver/processor with a low-frequency-effect (LFE) output:

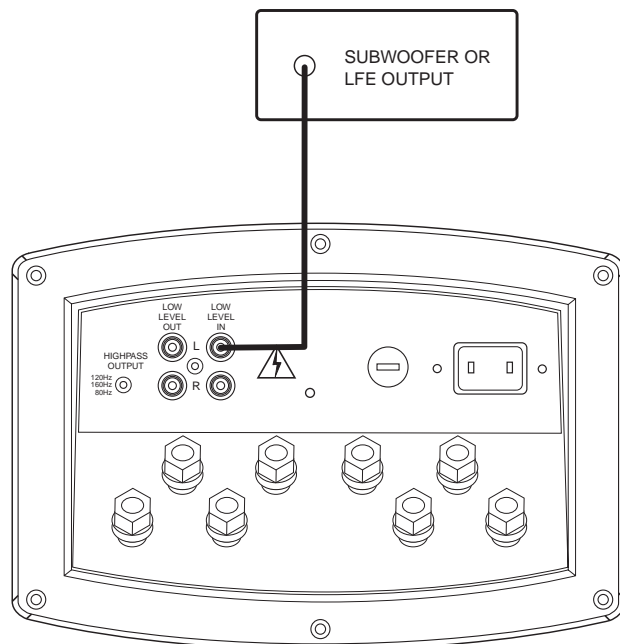

If your receiver/amplifier has preamp output jacks and main input jacks for the left and right channels or you have a separate preamp/processor and power amplifier:

This method of hookup can offer the highest level of performance for your complete loudspeaker system. Your subwoofer incorporates an adjustable high-pass crossover *in addition* to a variable low-pass crossover. When hooked up as shown below, the subwoofer will limit the low-frequency information that is returned to your receiver/amplifier. Your receiver/amplifier does not need to waste valuable power reproducing the low frequencies. In addition, since no low-frequency information is being sent to your main loudspeakers, they are able to reproduce mid and high frequencies with greater clarity.

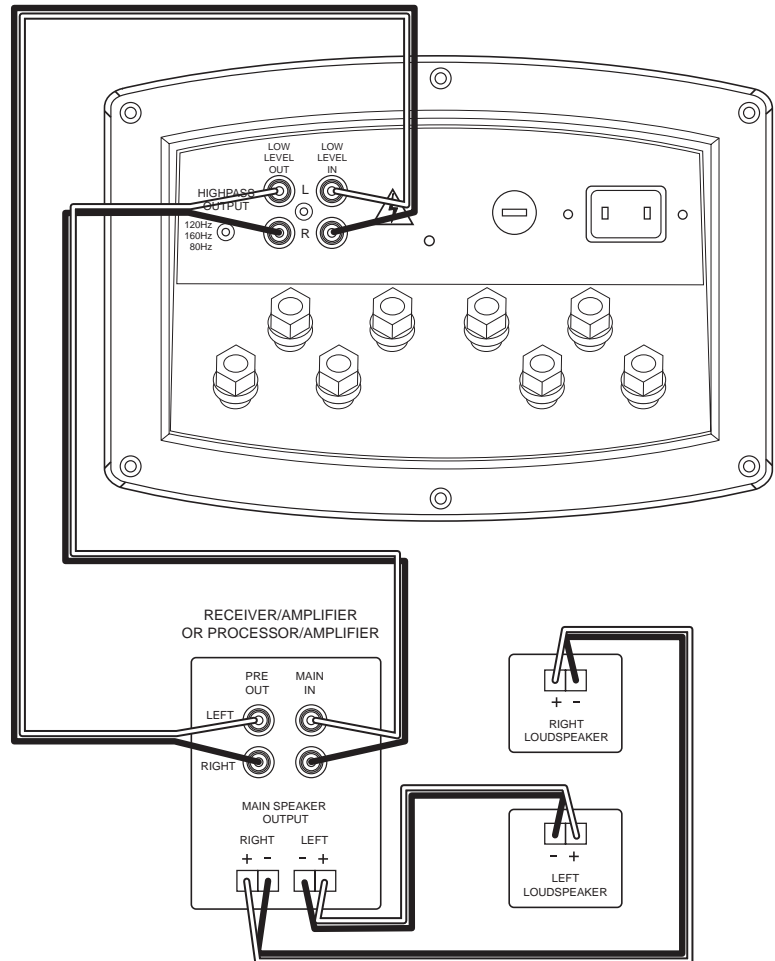

IDENTIFICATION OF FRONT PANEL CONTROL

CONTROLS...

(Refer to Figure 2.)

1. EQ: Optimizes subwoofer performance for audio or video playback.
2. Crossover: Controls the frequency below which the subwoofer will begin working.
3. Phase: Reverse/normal switch changes audio-signal polarity.
4. Gain: Controls subwoofer volume level.
5. Input: Switches between the normal line/speaker inputs and the direct-LFE input.

Figure 2.

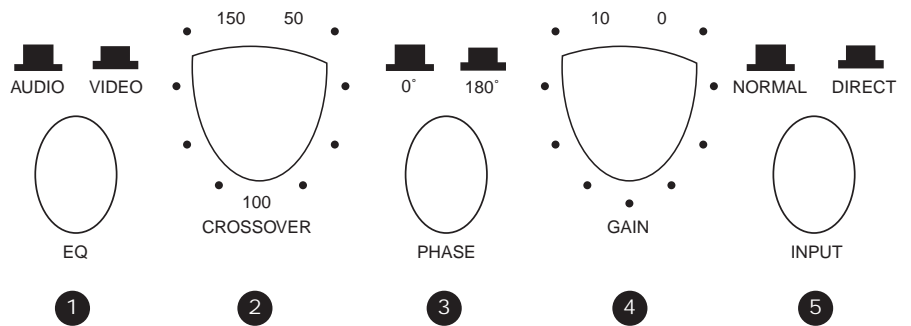

SET CONTROLS...

POWER ON...

ADJUST GAIN...

CROSSOVER ADJUSTMENTS...

PHASE CONTROL...

OPERATION

1. Initially set the HPS's Gain control to the "O" position.
2. Initially set the HPS's Crossover control to the 100Hz position.
3. Plug your HPS's AC cord into a wall outlet. Do not use the outlets on the back of the receiver.
4. Turn on your HPS sub by pressing the power button on the center of the front panel.
5. Turn on your entire audio system and start a CD or movie sound track at a moderate level.
6. Turn your HPS's Gain control ④ (Figure 2) up to the "5" position (half way). If no sound emanates from the subwoofer, check the AC-line cord and input cables. Are the connectors on the cables making proper contact? Is the AC plug connected to a "live" receptacle? Has the power button been pressed to the "on" position? (Note: A green indicator on the front panel will light when the power is on.) Once you have confirmed that the subwoofer is active, proceed by playing a CD, record or cassette. Use a selection that has ample bass information.
7. Set the overall volume control of the preamplifier or stereo to a comfortable level. Adjust the subwoofer's Gain control ④ (Figure 2) until you obtain a pleasing blend of bass. Bass response should not overpower the room but rather be adjusted so there is a harmonious blend across the entire musical range. Many users have a tendency to set the subwoofer volume too loud, adhering to the belief that a subwoofer is there to produce lots of bass. This is not entirely true. A subwoofer is there to enhance bass, extending the response of the entire system so the bass can be felt as well as heard. However, overall balance must be maintained or the music will not sound natural. An experienced listener will set the volume of the subwoofer so its impact on bass response is always there but never obtrusive.
8. Crossover Control ② (Figure 2) – The Low-Pass control determines the highest frequency at which the subwoofer reproduces sounds. If your main speakers can comfortably reproduce some low-frequency sounds, set this control to a lower frequency setting, between 50Hz – 100Hz. This will concentrate the subwoofer's efforts on the ultradeep bass sounds required by today's films and music. If you are using smaller bookshelf speakers that do not extend to the lower bass frequencies, set the low-pass crossover control to a higher setting, between 120Hz – 150Hz.
9. The Phase Control ③ (Figure 2) determines whether the subwoofer speaker's piston-like action moves in and out with the main speakers, 0°, or opposite the main speakers, 180°. Proper phase adjustment depends on several variables such as room size, subwoofer placement and listener position. Adjust the phase switch to maximize bass output at the listening position.
10. The EQ switch, located on the front panel, optimizes the subwoofer's performance for both movie and music listening. When in the "Video" position, a special EQ circuit is activated, enhancing low frequencies by approximately 3dB at 32Hz and delivering the full impact and excitement of today's movie soundtracks. When in the "Audio" position, the subwoofer provides the accurate and linear frequency response that is ideal when a natural tonal balance is desired for music listening.
11. Remember: every system, room and listener is different. There are not necessarily any right or wrong settings; any setting you choose will result in excellent performance. Should you decide to fine-tune your system for optimum performance, be patient and trust your ears. It will be worth the effort involved to fully "tweak" your system.

A WORD OF ADVICE

The low-frequency Crossover and Volume controls may be set anywhere within their rotation. However, it will be a most unusual circumstance if you have to set the Volume control completely clockwise. This may indicate an unbalanced condition in your system (too much bass), that the system is in an especially large room, or that speaker placement may be incorrect. Try several other locations before concluding that the Volume control must be set at maximum.

OVERDRIVE PROTECTION

Automatic limiting circuitry helps prevent overdriving a connected subwoofer by softly clipping the input signal if it exceeds a predetermined threshold. Depending on the level, you may or may not hear slight distortion on musical peaks. This protection is completely automatic, with no user adjustments. However, if you do hear distortion continuously while playing music, the input signal level (feeding the HPS) may be too high and should be lowered. If this doesn't solve the problem, check the connections and that the other components in the audio chain are operating properly.

A WORD ABOUT TONE CONTROLS

The tone controls on your electronic components (preamplifier, receiver, etc.) should be used with the utmost discretion. Excessive boost can create severe power demands on your power amplifier. Maximum bass boost can create a demand for literally hundreds of watts in the bass region, whereas in the "flat" position, or with the tone controls switched out of the system, your average listening level may be impressively and realistically loud at fewer than 10 watts. The remaining power capacity required is on reserve for power peaks on sharp transients and powerful crescendos.

HPS500 PARTS LIST

AMP ASSEMBLY #333777-001

Power supply PCB

Part #	Description	Qty	Ref. Designator
Integrated Circuits			
UA0003	OPAMP, QUAD 14PIN DIL LM324N	1	EA U3
UP0004	PWM, 8PIN DIL UC3842N	1	EA U5
Transistors			
QB0002	TRANS, NPN 40V .6A TO92 2N4401	3	EA Q4,Q13,Q14
QB0017	TRANS, NPN 150V 0.6A 2N5551	3	EA Q1,Q8,Q23
QB0018	TRANS, PNP 150V 0.6A 2N5401	3	EA Q7,Q22,Q26
QB0013	TRANS, PNP TIP30B/C TO220	1	EA Q21
QB0019	TRANS, NPN TIP29B/C TO220	1	EA Q19
QB0033	TRANS, NPN 250V 1A TO220 TIP47	1	EA Q3
QM0015	MOSFET, IRF640 TO220AB	2	EA Q9,Q27
Capacitors			
CC0020	CAP, CA 470PF 100V 5%	2	EA C3,C73
CC0059	CAP, CA .1UF 100V 20%	3	EA C13,C35,C65
CC0065	CAP, CA 2200P 50V 5%	3	EA C6,C19,C20
CC0072	CAP, CA 100PF 100V 10%	1	EA C74
CC0082	CAP, CA .1UF 50V 20%	4	EA C55,C56,C80,C81
CC0087	CAP, CA .01UF 100V 20%	1	EA C28
CC0021	CAP, C 470PF 1KV 10%	3	EA C2,C9,C11
CC0032	CAP, C 2200PF 600V 10%	1	EA C14
CC0050	CAP, C .1UF 50V 20% .2LS	1	EA C24
CC0078	CAP, C .22UF 50V 10% .2LS	1	EA C17
CC0095	CAP, C 470P 100V 5	2	EA C22,C23
CE0010	CAP, E 22UF 50V 20% 105C	2	EA C4,C79
CC0020	CAP, CA 470PF 100V 5%	1	EA C10
CC0078	CAP, C .22UF 50V 10% .2LS	1	EA C17
CE0121	CAP, E 470UF 200V 20% 30X25	5	EA C30,C31,C32,C33,C34
CF0008	CAP, F 2200PF 100DC 63AC 5%	1	EA C21
CF0146	CAP, F 6.8UF 250V 10% 27MMLS	1	EA C12
Diodes			
DS0001	RECT, 100mA 75V SIGNAL 1N4148T	7	EA D2,D5,D6,D7,D12,D24,D25
DZ0002	ZENER, 500mW 12V 5% 1N5242B	3	EA Z1,Z5,Z6
DR0085	RECT, 8A 400V TO220AC MUR860	1	EA D9
DZ0018	ZENER, 2.5-37V SHUNT TL431CLP	1	EA D23

Part #	Description	Qty	Ref. Designator
Resistors			
RC0006	RES, CF 10K 1/4W 5%	1	EA R17
RC0037	RES, CF 2K0 1/4W 5%	1	EA R3
RC0082	RES, CF 100K 1/2W 5%	1	EA R77
RC0083	RES, CF 100K 1/4W 5%	2	EA R25,R51
RC0091	RES, CF 150K 1/2W 5%	1	EA R94
RC0116	RES, CF 330K 1/4W 5%	1	EA R12
RC0127	RES, CF 30K 1/4W 5%	2	EA R8,R38
RC0273	RES, ZERO OHM 1/4W	1	EA R24
RM0001	RES, MF 1K00 1/4W 1%	4	EA R30,R50,R68,Z4
RM0002	RES, MF 10K0 1/4W 1%	1	EA R71
RM0011	RES, MF 100K 1/4W 1%	6	EA R5,R6,R10,R11,R28,R70
RM0012	RES, MF 100R 1/4W 1%	1	EA R54
RM0031	RES, MF 3K32 1/4W 1%	1	EA R43
RM0034	RES, MF 4K32 1/4W 1%	1	EA R16
RM0035	RES, MF 4K75 1/4W 1%	1	EA R45
RM0043	RES, MF 6K81 1/4W 1%	1	EA R74
RM0065	RES, MF 200R 1/4W 1%	1	EA R49
RM0079	RES, MF 750R 1/4W 1%	2	EA R9,R13
RM0089	RES, MF 2K43 1/4W 1%	1	EA R41
RM0113	RES, MF 20K0 1/4W 1%	4	EA R14,R15,R35,R88
RM0114	RES, MF 22K1 1/4W 1%	1	EA R72
RM0116	RES, MF 25K5 1/4W 1%	1	EA R46
RM0120	RES, MF 30K1 1/4W 1%	2	EA R7,R47
RM0126	RES, MF 47K0 1/4W 1%	1	EA R26
RM0147	RES, MF 16K2 1/4W 1%	1	EA R22
RM0180	RES, MF 4K99 1/4W 1%	3	EA R2,R27,R37
RM0249	RES, MF 28K7 1/4W 1%	1	EA R4
RM0260	RES, MF 1M0 1/4W 1%	1	EA R32
RM0299	RES, MF 2K55 1/4W 1	1	EA R31
RM0336	RES, MF 47R 0.6W 1% FLAMEPROOF	4	EA R18,R39,R89,R90
RM0339	RES, MF 10R 0.6W 1% FLAMEPROOF	2	EA R21,R93
RW0022	RES, WW 0R1 2W 5%	2	EA R40,R92
RX0072	RES, MO 100R 1W 5%	1	EA R19
RC0273	RES, ZERO OHM 1/4W	1	EA L3
RX0080	RES, MO 4R7 2W 5%	1	EA R20

Part #	Description	Qty	Ref. Designator
Miscellaneous			
540130	IND, CM CHOKE 150UH ELYTONE	1	EA L4
BF0007	BEAD, FERRITE	1	EA L5
JH0074	CNCTR, HEADER 8PIN LOCKING .1C	1	EA J3
KS0021	SURGISTOR, 4R 8A 70J SL154R008	1	EA R23
MM0025	MISC, PC MT SCREW TERM 6-32	2	EA B1,B2
MT0003	TERM, KWIKDISC .25 PCB MT	2	EA CD+,DC+
MT0023	TERM, FASTON MALE PCMT 187X032	1	EA CD-
MT0031	TERM, FASTON .205 MALE PC MT	1	EA DC-
810066	MET, HTSNK CLIP HPS SERIES	6	EA FET CLIPS ON THE POWER BOARD
810068	MET, HTSNK HPS500 PWR SUPPLY	1	EA HEATSINK PLATE FOR THE POWER B
HN0006	NUT, KEP 1/4AF 6-32 ZNP	1	EA USED ON L4 (540130)
HS0004	SCREW, 6-32 1/4 PAN PHIL ZNP	2	EA USED ON MM0025
HS0079	SCREW, 6-32 1.5 NYLON PAN	1	EA USED ON L4 (540130)
HW0030	WASHER, FLAT .375OD #8 NYLON	1	EA USED ON THE L4 (540130)
MS0005	SILPAD, .009" .3C/W TO3P	5	EA USED WITH 5 FETS
MS0014	MISC, CERAMIC PLATE TO-220	1	EA USED WITH 1 FET

Linear Amp PCB

Integrated Circuits

UA0003	OPAMP, QUAD 14PIN DIL LM324N	2	EA U101,U102
UA0009	OPAMP, QUAD 14P DIL TL074/084	2	EA U1,U100
UF0013	FOTO, 6PIN MOC3012	1	EA U4

Transistors

QM0015	MOSFET, IRF640 TO220AB	2	EA Q4,Q8
QM0032	MOSFET, IRF9640 T0220AB	2	EA Q3,Q7
QM0035	JFET, N-CH J111 TO92	1	EA Q9
QB0002	TRANS, NPN 40V .6A TO92 2N4401	1	EA Q101
QB0017	TRANS, NPN 150V 0.6A 2N5551	2	EA Q1,Q5
QB0018	TRANS, PNP 150V 0.6A 2N5401	2	EA Q2,Q6
QB0049	TRANS, TO92 2N3819	1	EA Q100

Capacitors

CC0059	CAP, CA .1UF 100V 20%	4	EA C52,C54,C57,C58
CC0072	CAP, CA 100PF 100V 10%	2	EA C1,C3
CC0082	CAP, CA .1UF 50V 20%	6	EA C29,C61,C62,C110,C120,C121
CC0098	CAP, CA .047U 50V 10	2	EA C109,C122
CE0127	CAP, E 470UF 35V 10X21	1	EA C127

Part #	Description	Qty	Ref. Designator
CF0090	CAP, F .022UF 100V 5% 10MMLS	1	EA C102
CF0094	CAP, F .047UF 100V 5% 10MM	1	EA C122
CE0003	CAP, E 2.2UF 50V 20% 105C	1	EA C111
CE0098	CAP, E 22UF 50V 20% 5X11 .2LS	5	EA C6,C50,C64,C67,C68
CE0106	CAP, E 22UF 35V BP 6X11 .2LS	4	EA C8,C9,C12,C101
CF0035	CAP, F .022UF 100V 5% 5MMLS	1	EA C108
CF0045	CAP, F .1UF 63DC 5% 5MMLS	9	EA C5,C7,C10,C11,C103,C104,C105,C106
CF0099	CAP, F .68U 63V 5	1	EA C100
CF0119	CAP, F .047UF 100V 5% 5MM	2	EA C2,C4
Diodes			
DS0001	RECT, 100mA 75V SIGNAL 1N4148T	28	EA D1,D2,D3,D4,D5,D6,D7,D8,D9,D10
DZ0021	ZENER, 500MW 15V 5% 1N5245B	2	EA Z1,Z2
Resistors			
RC0001	RES, CF 1K0 1/2W 5%	1	EA R140
RC0004	RES, CF 1M0 1/4W 5%	1	EA R130
RC0006	RES, CF 10K 1/4W 5%	8	EA R39,R60,R121,R122,R123,R124,R146
RC0037	RES, CF 2K0 1/4W 5%	2	EA R127,R131
RC0083	RES, CF 100K 1/4W 5%	2	EA R16,R128
RC0127	RES, CF 30K 1/4W 5%	1	EA R143
RC0197	RES, CF 3K6 1/2W 5%	1	EA R38
RC0273	RES, ZERO OHM 1/4W	5	EA R32,R113,R119,C126,D110
RM0001	RES, MF 1K00 1/4W 1%	4	EA R2,R34,R108,R120
RM0002	RES, MF 10K0 1/4W 1%	5	EA R125,R129,R149,R150,R151
RM0011	RES, MF 100K 1/4W 1%	2	EA R136,R137
RM0024	RES, MF 2K21 1/4W 1%	4	EA R10,R11,R25,R26
RM0029	RES, MF 3K01 1/4W 1%	2	EA R15,R30
RM0031	RES, MF 3K32 1/4W 1%	4	EA R4,R5,R19,R20
RM0039	RES, MF 5K11 1/4W 1%	1	EA R22
RM0041	RES, MF 61K9 1/4W 1%	1	EA R148
RM0043	RES, MF 6K81 1/4W 1%	4	EA R3,R6,R18,R21
RM0071	RES, MF 332R 1/4W 1%	4	EA R8,R9,R23,R24
RM0072	RES, MF 365R 1/4W 1%	1	EA R102
RM0073	RES, MF 392R 1/4W 1%	2	EA R33,R85
RM0075	RES, MF 475R 1/4W 1%	1	EA R120
RM0093	RES, MF 4K53 1/4W 1%	5	EA R7,R58,R61,R62,R63
RM0103	RES, MF 10K5 1/4W 1%	2	EA R31,R84

Part #	Description	Qty	Ref. Designator
RM0113	RES, MF 20K0 1/4W 1%	2	EA R35,R36
RM0129	RES, MF 53K6 1/4W 1%	2	EA R14,R29
RM0134	RES, MF 121K 1/4W 1%	1	EA R145
RM0170	RES, MF 59K 1/4W 1%	1	EA R147
RM0180	RES, MF 4K99 1/4W 1%	1	EA R144
RM0183	RES, MF 12K4 1/4W 1%	1	EA R111
RM0191	RES, MF 20K5 1/4W 1%	2	EA R106,R107
RM0198	RES, MF 205K 1/4W 1%	1	EA R114
RM0255	RES, MF 7K15 1/4W 1%	1	EA R101
RM0304	RES, MF 7K87 1/4W 1%	1	EA R37
RM0307	RES, MF 1K15 1/4W 1%	1	EA R109
RM0315	RES, MF 2K67 1/4W 1%	1	EA R100
RM0359	RES, MF 34K8 1/4W 1%	1	EA R110
RM0363	RES, MF 24K3 1/4W 1%	3	EA R105,R115,R117
RM0364	RES, MF 1K91 1/4W 1%	1	EA Z100
RX0074	RES, MO 4K7 1W 5	2	EA R12,R27
RM0260	RES, MF 1M0 1/4W 1%	1	EA C112
RP0056	POT, 5K 8MM HOR TOP ADJ/COVER	2	EA R13,R28
RP0063	POT, A10K SINGLE/BRACKET	1	EA R103
RP0065	POT, B50K DUAL / BRACKET +/- 10%	1	EA R116
RX0097	RES, MO 3K9 2W 5%	1	EA R38
Miscellaneous			
JH0028	CNCTR, HEADER 3PIN .100CTR	1	EA SHIELD
JH0063	CNCTR, HEADER 3PIN .1CTR	1	EA J100
JH0074	CNCTR, HEADER 8PIN LOCKING .1C	1	EA J3
KS0019	THERMISTOR, PTH9L04BD22TS2F510	1	EA TH1
MM0025	MISC, PC MT SCREW TERM 6-32	4	EA B1,B2,B3,B4
MT0003	TERM, KWIKDISC .25 PCB MT	2	EA CD-,SPKR-
MT0031	TERM, FASTON .205 MALE PC MT	2	EA SPKR+,CD+
SR0017	SWITCH, 2 POLE 2PDT	3	EA SW3,SW4,SW5
810066	MET, HTSNK CLIP HPS SERIES	4	EA CLIPS FOR FETS
810070	MET, HTSNK LEFT HPS500 FEA/LIN	1	EA LEFT SIDE HEATSINK
810071	MET, HTSNK RIGHT HPS500 F/L	1	EA RIGHT SIDE HEATSINK
HS0004	SCREW, 6-32 1/4 PAN PHIL ZNP	4	EA USED WITH MM0025
AC Power PCB			
520025	XFMR, CURRENT YT-7102-1	1	EA L2
540124	IND, CM CHOKE	1	EA L1

Part #	Description	Qty	Ref. Designator
CE0004	CAP, E 2.2UF 450V 20% 85C	1	EA C9
CF0057	CAP, FX .22UF 250V 10%	1	EA C5
DB0009	RECT, 6A 400V BRIDGE	1	EA D1
JH0044	CNCTR, HEADER 3PIN .156CTR	1	EA J1
KV0001	VARIATOR, 275V 100J .6W	1	EA Z1
MT0003	TERM, KWIKDISC .25 PCB MT	1	EA DC+
MT0031	TERM, FASTON .205 MALE PC MT	1	EA DC-
RC0004	RES, CF 1M0 1/4W 5%	1	EA R1
SR0009	SWITCH, PUSH TV5	1	EA SW3
Shield board PCB			
DL0021	LED, 3MM GREEN	2	EA LED1,LED2
JC0118	CNCTR, 3PIN LED HARNESS 4"	1	EA J1
MZ0026	STANDOFF, 7.5MM LED 2PIN	2	EA TO SUPPORT THE LED
Final assembly			
DL0023	LED, REFLECTOR	1	EA TO BE USED ON THE AMP HOUSING
HS0072	SCREW, #4 HI-LOW PAN PHIL ZNP	6	EA USED TO ATTACH THE CABLE TIE A
HS0073	SCREW, #6 HI-LOW PAN PHIL ZNP	12	EA 4PC ON FEATURE LINEAR BOARD 4PC ON CLASS D BOARD 4PC USED WITH MC0003
JC0071	CNCTR, FEM-FEM HARNESS 8PIN 9"	1	EA FROM CLASS D TO FEA/LIN BOARD
JC0114C	CNCTR, 3PIN MALE/3PIN FEM LOCK	1	EA AC CONNECT TO JC0114A ON INPUT
JC0117C	CNCTR, 3PIN FEM/3PIN FEM 47.5"	1	EA CONNECT TO JC0117A ON THE INPU
JC0135	CNCTR, CLASSD PWR CBL 5.75/6.5	1	EA CD+/- FROM CLASS D BD TO FEA/L
JC0136	CNCTR, DC POWER CABLE 4.25"/5"	1	EA DC+/- FROM CLASS D BD TO AC PW
JC0137	CNCTR, SPEAKER CABLE 21"/23"	1	EA ON THE FEA/LIN BOARD
MC0003	CABLE, TIE 40MM W/ METAL RING	4	EA CABLE TIE WITH RING TERMINALS
RP0076	POT, KNOB FOR HPS SERIES	2	EA KNOBS FOR THE POTS
RP0077	POT KNOB FOR HPS SWITCH	3	EA KNOB FOR THE PUSH SWITCH
RP0078	POT KNOB FOR HPS BUTTON	1	EA KNOB FOR THE POWER BUTTON
TS0017	FIBREGLASS, HT210 #2AWG 3"	1	EA SLEEVING FOR JC0137
Hi level Input components			
630021	PCB, INPUT HI-LVL HPS SERIES	1	EA
RC0118	RES, CF 15R 1/2W 5%	2	EA R2,R5
RM0085	RES, MF 2K00 1/4W 1%	2	EA R3,R6
CE0106	CAP, E 22UF 35V BP 6X11 .2LS	2	EA C1,C2
500086	XFMR, POWER AUDIO YT-6821	2	EA T1,T2
CF0143	CAP, FY1 4700PF 250V 20	2	EA C3,C4

Part #	Description	Qty	Ref. Designator
JC0139	CNCTR, HARNESS HI-LVL 8.5"	1	EA J1/J2
RW0037	RES, WW 470R 5W 5	2	EA R1,R4
Input PCB			
630028	PCB, INPUT HPS500/1000	1	EA REVISION
CF0045	CAP, F .1UF 63DC 5% 5MMLS	4	EA C14,C15,C17,C18
CF0128	CAP, F .033UF 100V 5MMLS	2	EA C13,C16
RM0002	RES, MF 10K0 1/4W 1%	2	EA R12,R13
RM0029	RES, MF 3K01 1/4W 1%	2	EA R10,R11
500086	XFMR, POWER AUDIO YT-6821	1	EA T10
CE0106	CAP, E 22UF 35V BP 6X11 .2LS	1	EA C10
CF0143	CAP, FY1 4700PF 250V 20	1	EA C12
JC0052	CNCTR, RCA QUAD JACK	1	EA RCA1
JH0063	CNCTR, HEADER 3PIN .1CTR	2	EA J34,J36
MM0025	MISC, PC MT SCREW TERM 6-32	1	EA W5
SR0022	SWITCH, DPDT TOGGLE C/W CAP PC	1	EA SW1
630031	PCB, INPUT SHIELD HPS500/1K	1	EA
930035	CUP, OUTER PLASTIC HPS250	1	EA OUTER PLASTIC CUP
930039	CUP, INNER PLASTIC HPS500	1	EA INNER PLASTIC CUP
FH0010	FUSE, HOLDER PANEL MT RANGLE	1	EA ON THE INNER CUP
FS0026	FUSE, 4A 250V 1.25X.25 GLASS	1	EA FUSE
HN0001	NUT, KEP 3/16AF 4-40 ZNP	2	EA USED ON THE IEC CONNECTOR
HN0015	NUT, HEX KEP #8-32 ZNP	8	EA USED ON THE BINDING POSTS
HS0041	SCREW, SELF TAP #4 BLK OXIDE	1	EA USED ON THE RCA
HS0055	SCREW, #4-40X1/2 PAN PHIL BLK	2	EA USED ON THE IEC CONNECTOR
HS0065	SCREW, #6-32X1/4 PAN PHIL BLK	1	EA USED ON MM0025
HS0072	SCREW, #4 HI-LOW PAN PHIL ZNP	4	EA TO SECURE THE CUPS AND CABLE TIES
HS0074	SCREW, #4-40X3/4 PAN PHIL ZNP	2	EA BETWEEN SHIELD AND INPUT PCB
JC0076	CNCTR, AC IEC SOCKET .250TAB	1	EA ON THE INNER PLASTIC CUP
JC0086	CNCTR, SINGLE BINDING POST RED	4	EA ON THE INNER PLASTIC CUP
JC0087	CNCTR, SINGLE BINDING POST BLK	4	EA ON THE INNER PLASTIC CUP
JC0114A	CNCTR, 3PIN FEM/2XFEM FASTON	1	EA CONNECT TO MATING HARNESS ON PWR B
JC0117A	CNCTR, 3PIN FEM/3PIN MALE 11"	1	EA CONNECTO TO MATCHING HARNESS
MC0003	CABLE, TIE 40MM W/ METAL RING	2	EA TO SECURE CABLE TIES
MM0027	RUBBER GROMMETS	4	EA 2 ON THE TRANSFORMER
MZ0023	STANDOFF, .5" NYLON LOCKING	1	EA STANDOFF
MZ0028	STANDOFF, 1/2" AL ID.151 #409	1	EA BETWEEN INPUT SHIELD AND INPUT PCB
WI0032	WIRE, POWER CORD SPT2/IEC 8FT	1	EA POWER CORD

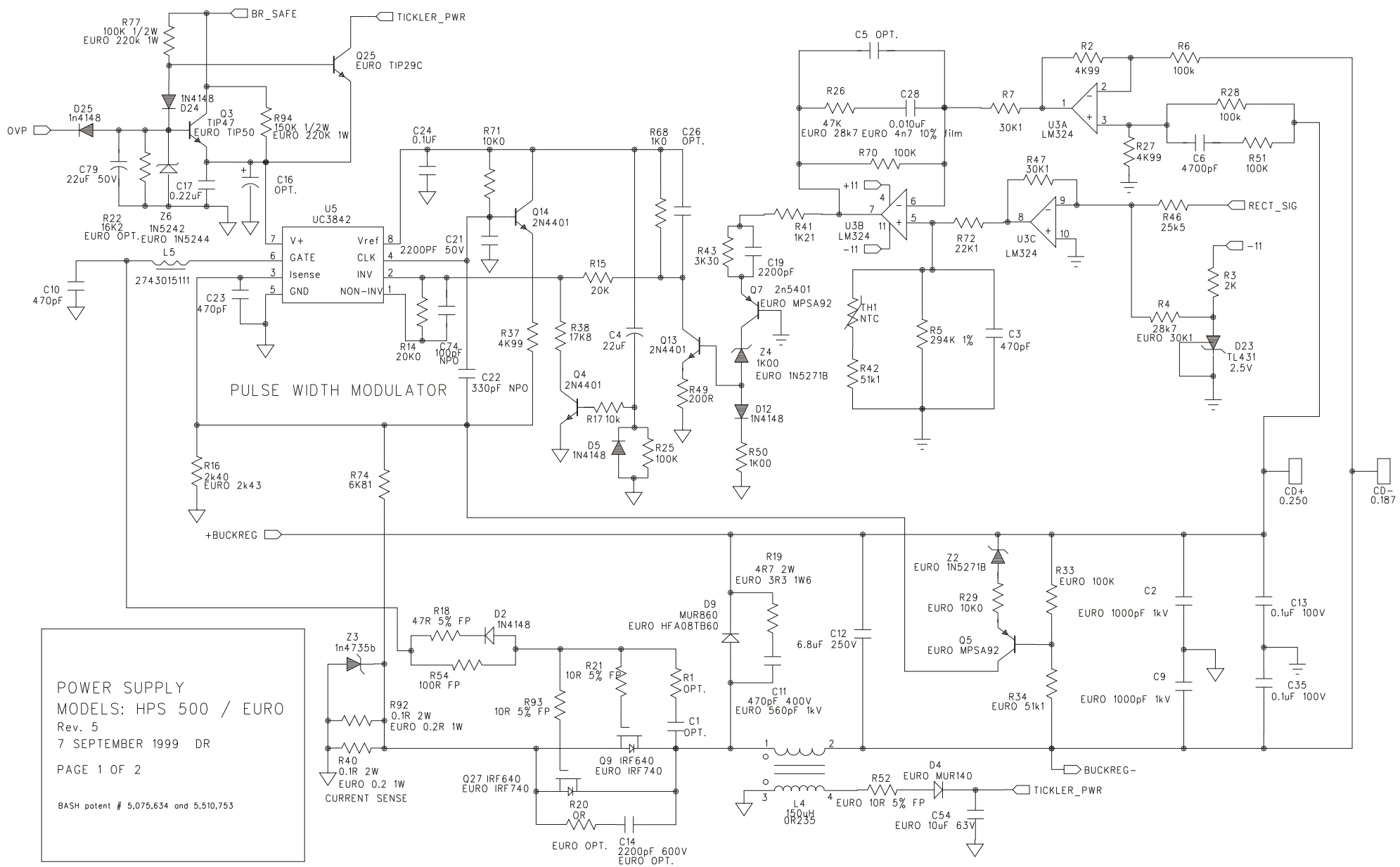

POWER SUPPLY
 MODELS: HPS 500 / EURO
 Rev. 5
 7 SEPTEMBER 1999 DR
 PAGE 1 OF 2
 BASH patent # 5,075,634 and 5,510,753

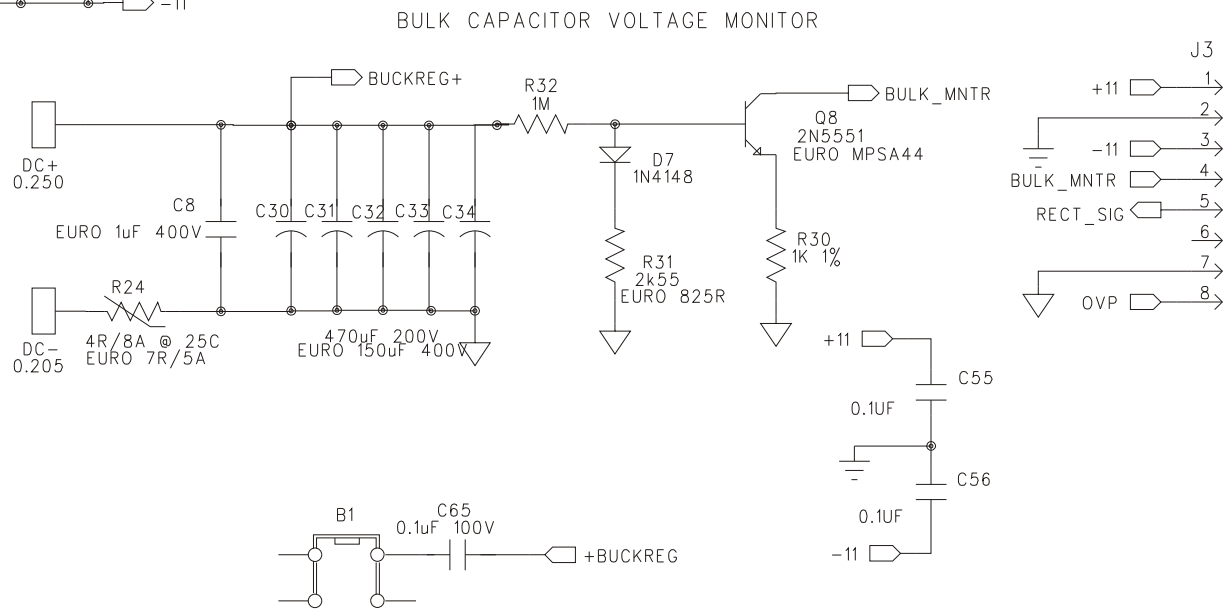
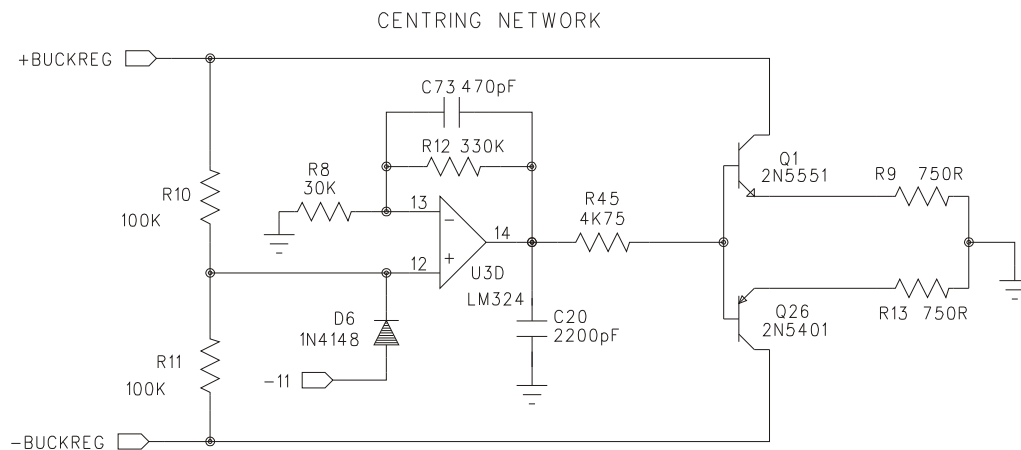
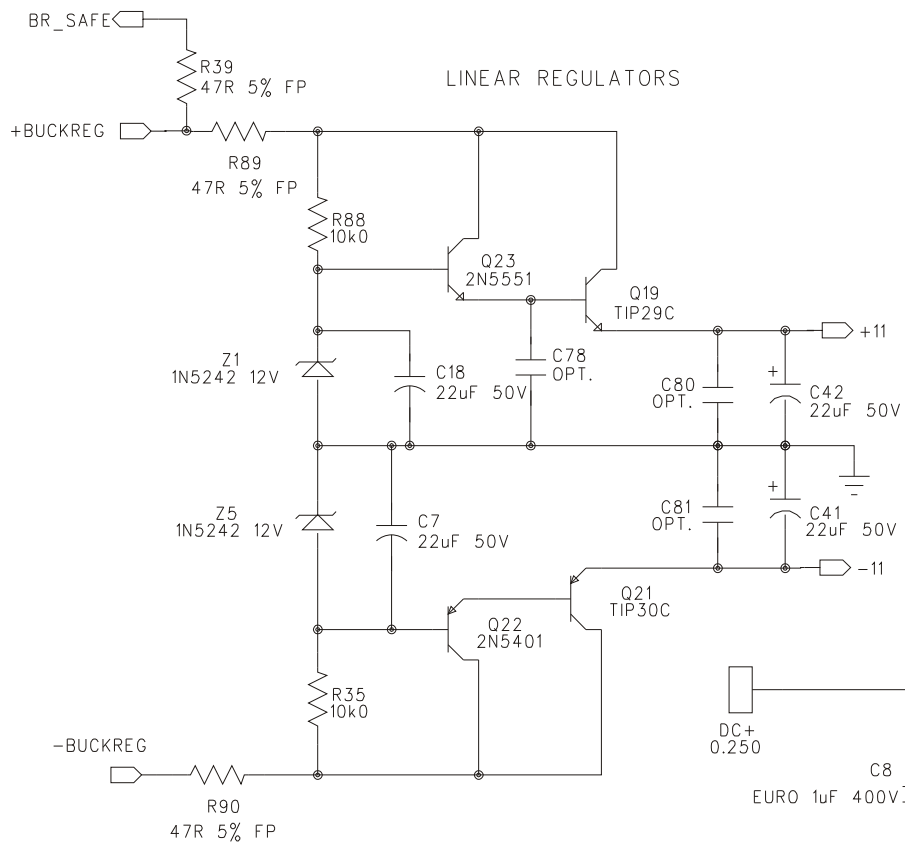

POWER SUPPLY
 MODELS: HPS 500 / EURO
 Rev. 5
 7 SEPTEMBER 1999 DR
 PAGE 2 OF 2
 BASH patent # 5,075,634 and 5,510,753

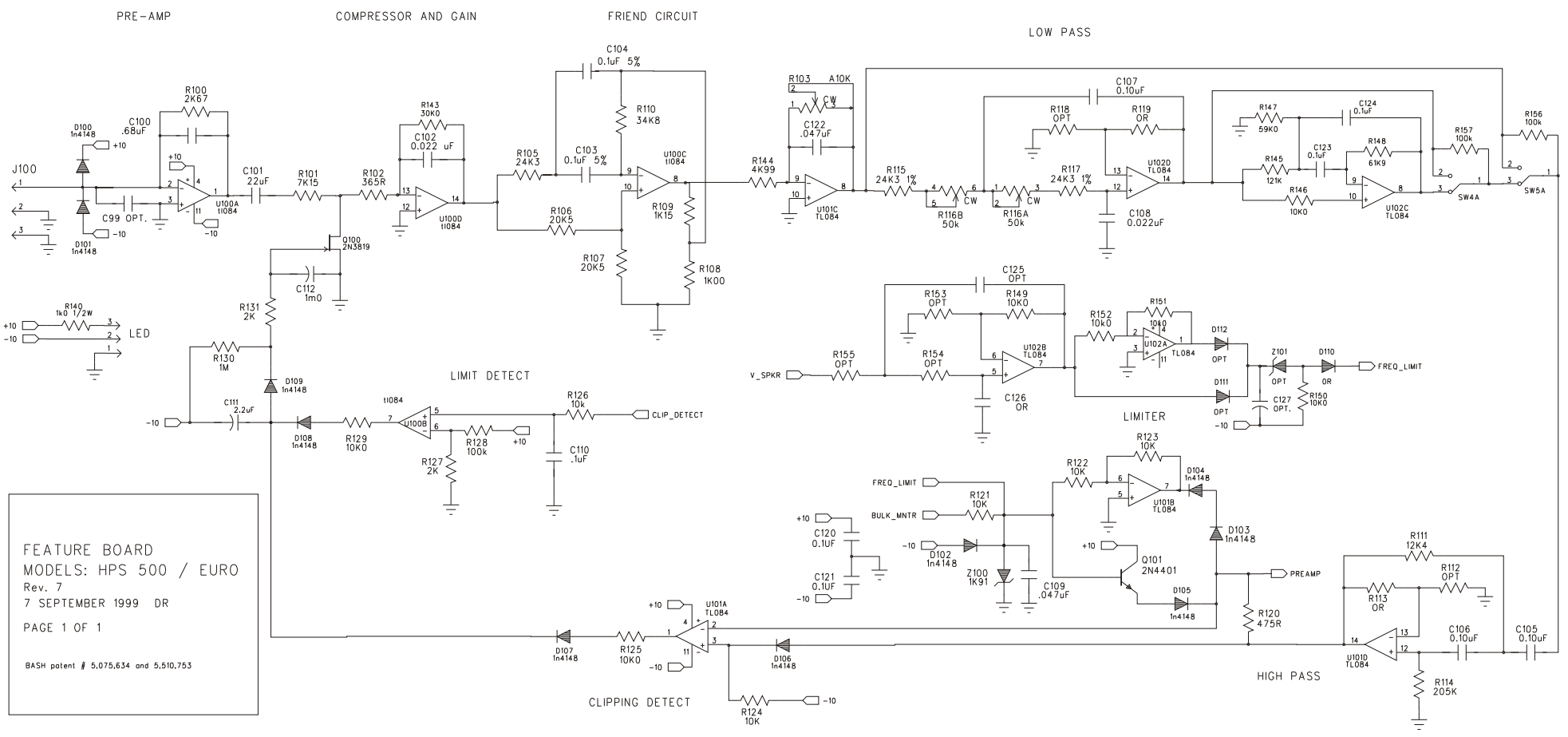

FEATURE BOARD
 MODELS: HPS 500 / EURO
 Rev. 7
 7 SEPTEMBER 1999 DR
 PAGE 1 OF 1
 BASH patent # 5,075,634 and 5,510,753

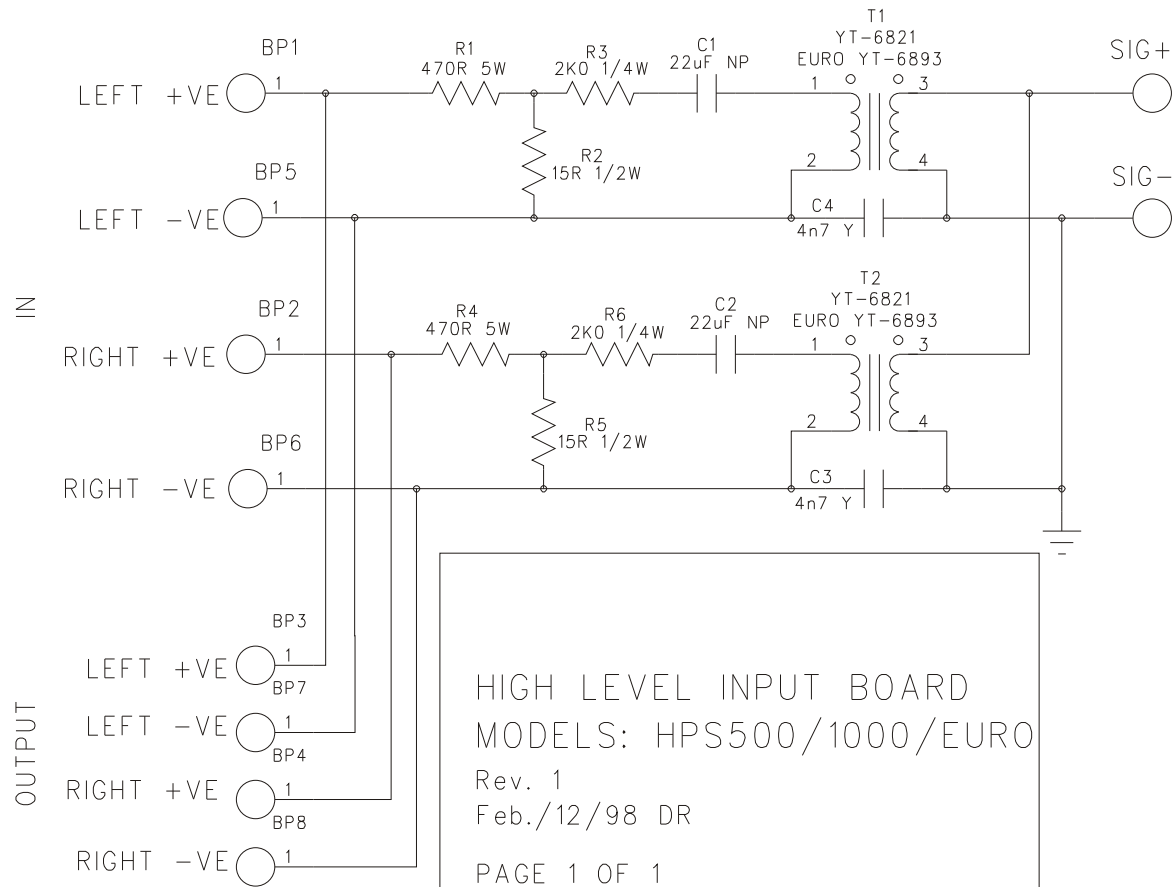

HIGH LEVEL INPUT BOARD
 MODELS: HPS500/1000/EURO
 Rev. 1
 Feb./12/98 DR
 PAGE 1 OF 1
 BASH patent # 5,075,634 and 5,510,753

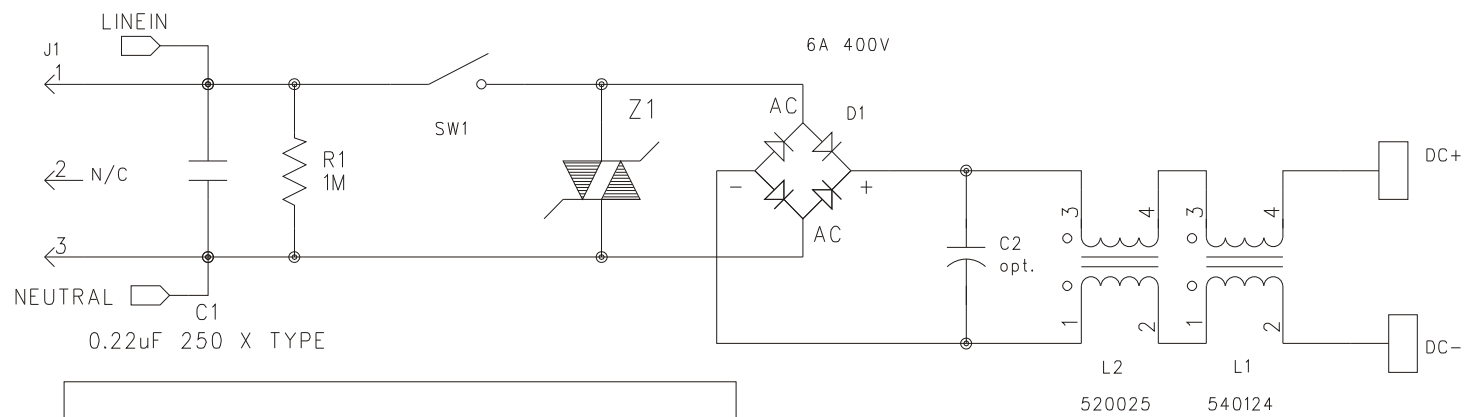

LINE FILTER BOARD
 MODELS: HPS500 / EURO

Rev. 2
 7 SEPTEMBER 1999 DR
 PAGE 1 OF 1

BASH patent # 5,075,634 and 5,510,753

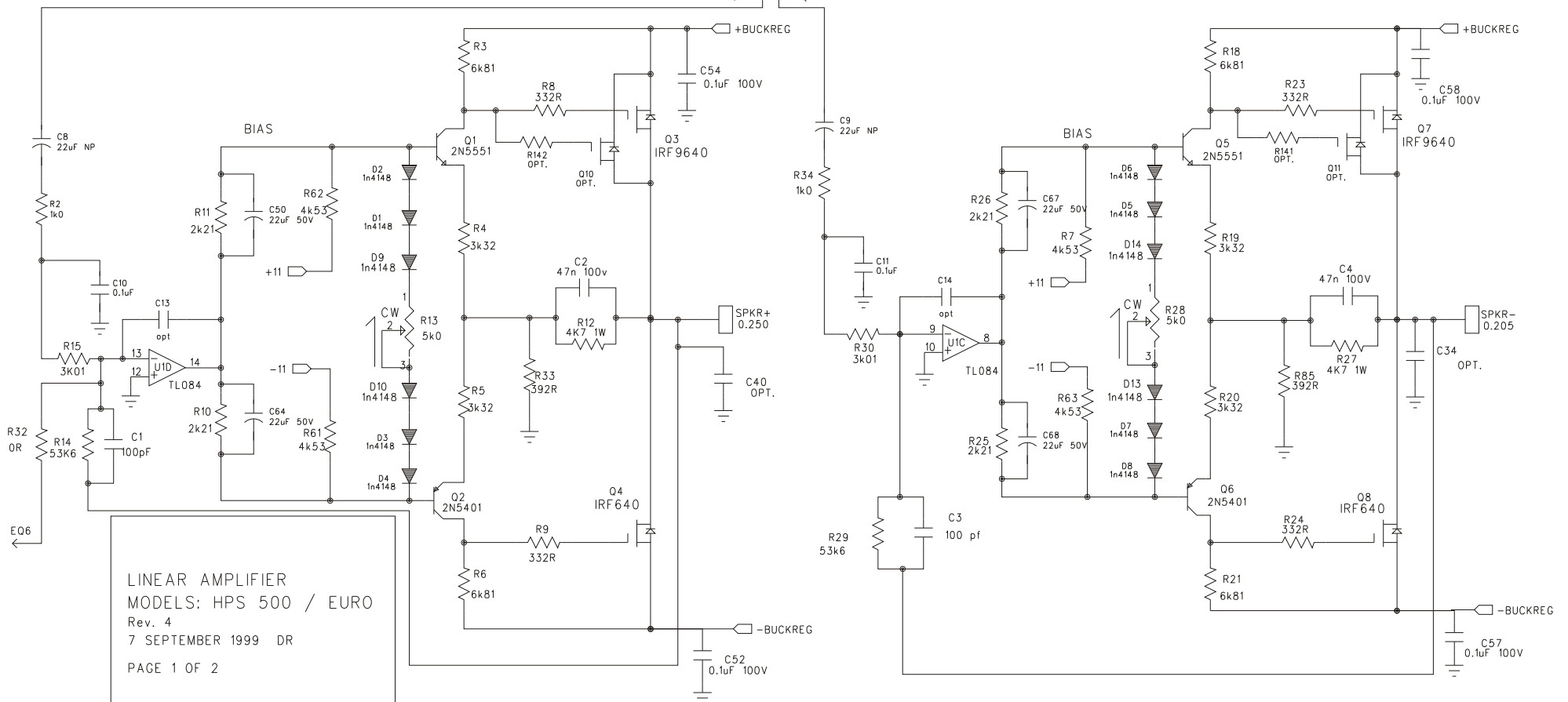
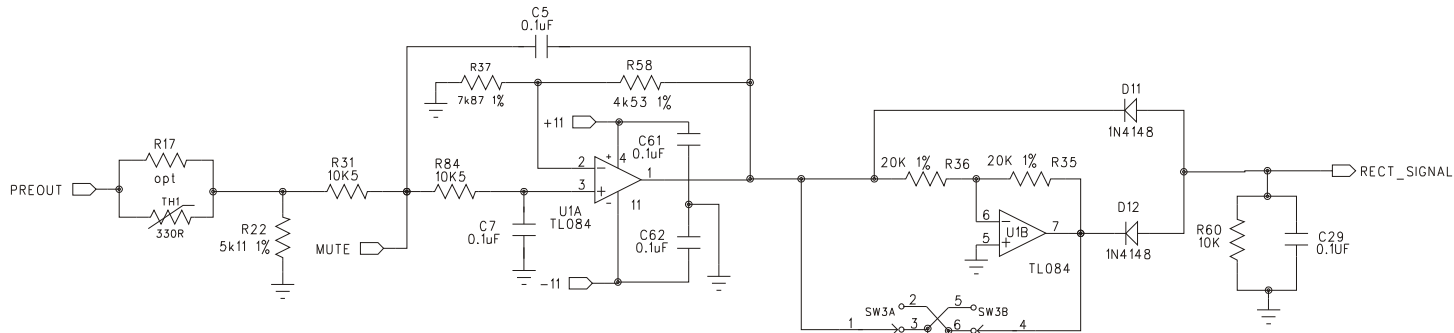

LINEAR AMPLIFIER
 MODELS: HPS 500 / EURO
 Rev. 4
 7 SEPTEMBER 1999 DR
 PAGE 1 OF 2

BASH patent # 5,075,634 and 5,510,753

LINEAR AMPLIFIER
 MODELS: HPS 500/EURO

Rev. 4

7 SEPTEMBER 1999 DR

PAGE 2 OF 2

BASH patent # 5,075,634 and 5,510,753

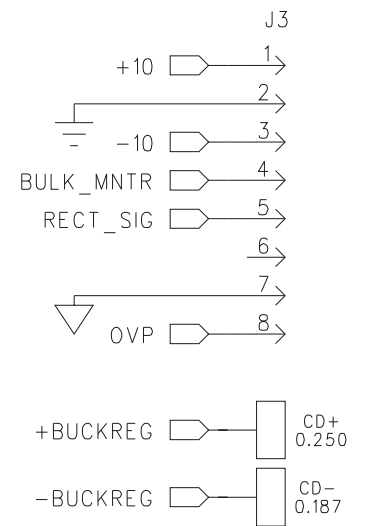
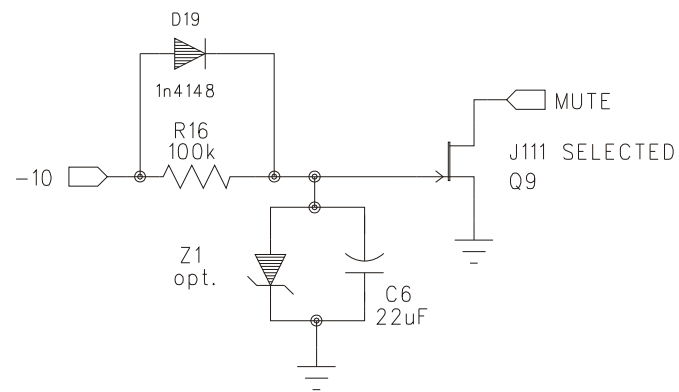
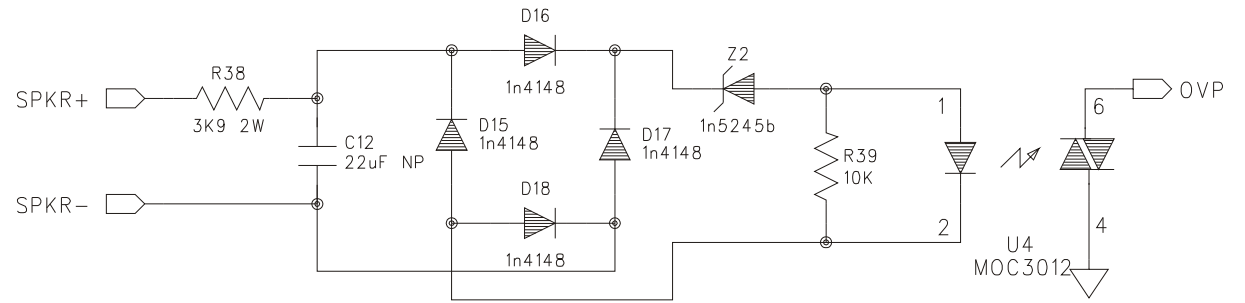

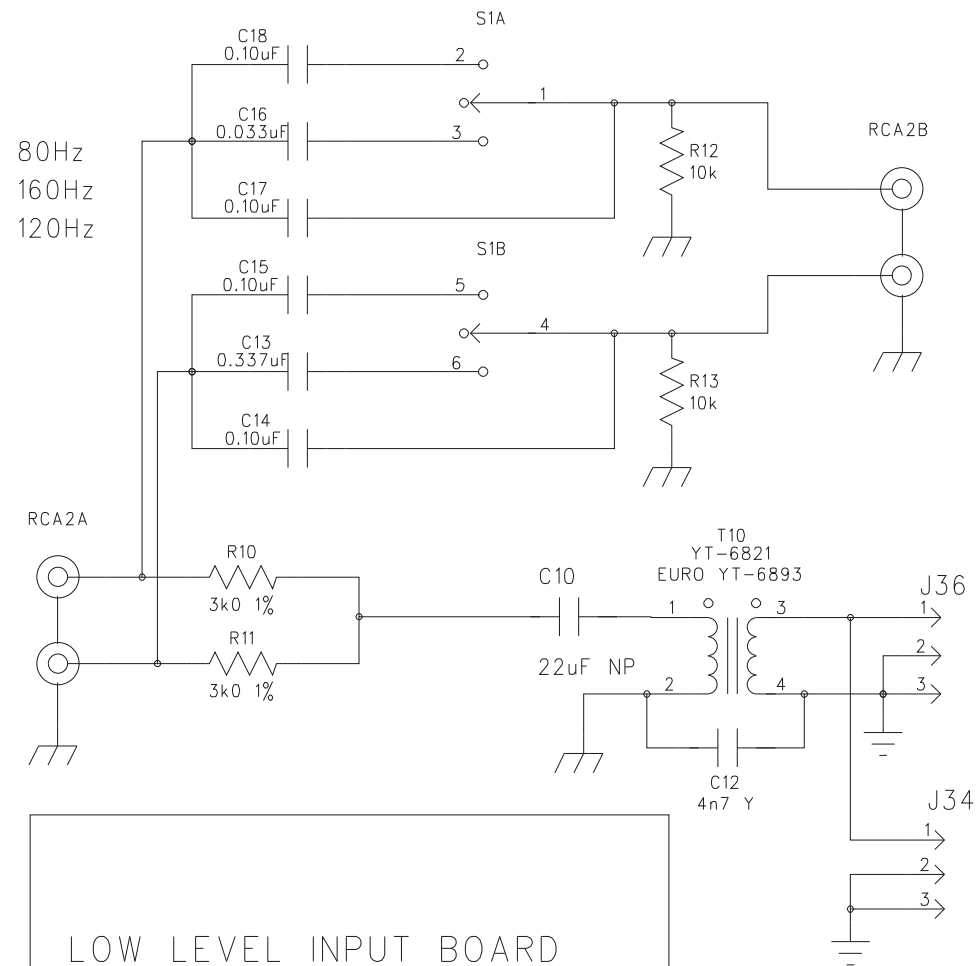

LOW LEVEL INPUT BOARD
 MODELS: HPS 500/1000/EURO
 Rev. 2
 Feb./11/98 DR
 PAGE 1 OF 1
 BASH patent # 5,075,634 and 5,510,753